

FOCUSAC
"wrap it"

**TABLALI STREÇ
SARMA MAKİNASI**
TURNTABLE STRETCH
WRAPPING MACHINE



@odaksan_muhendislik

www.odaksan.com



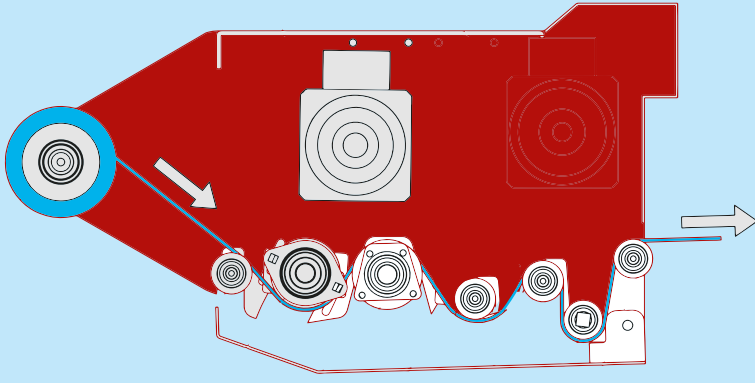

FOCUSACM "wrap it"

Tek Motorlu Öngerme
%300 veya %400 Sabit Öngerme
%50'ye Varan Streç Tasarrufu

Pre-Stretching Unit with Single Motor
Fixed 300% or 400% Pre-Stretching
Up to 50% Stretch Film Saving

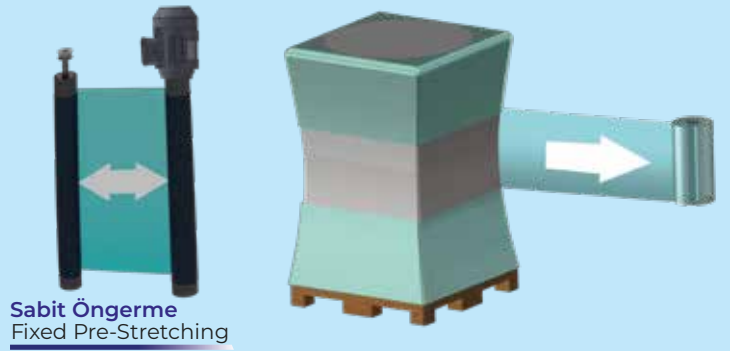

FOCUSACD "wrap it"

Çift Motorlu Öngerme
%200 - %500 Ayarlanabilir Öngerme
%75'e Varan Streç Tasarrufu

Double Motor Pre-stretching
Adjustable 200% to 500% Pre-Stretching
Up to 75% Stretch Film Saving

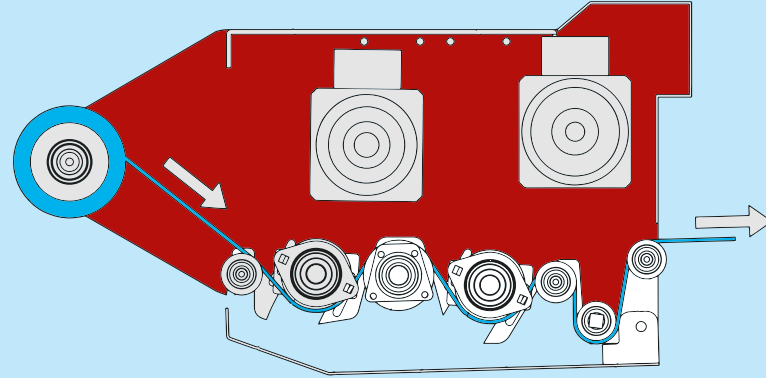

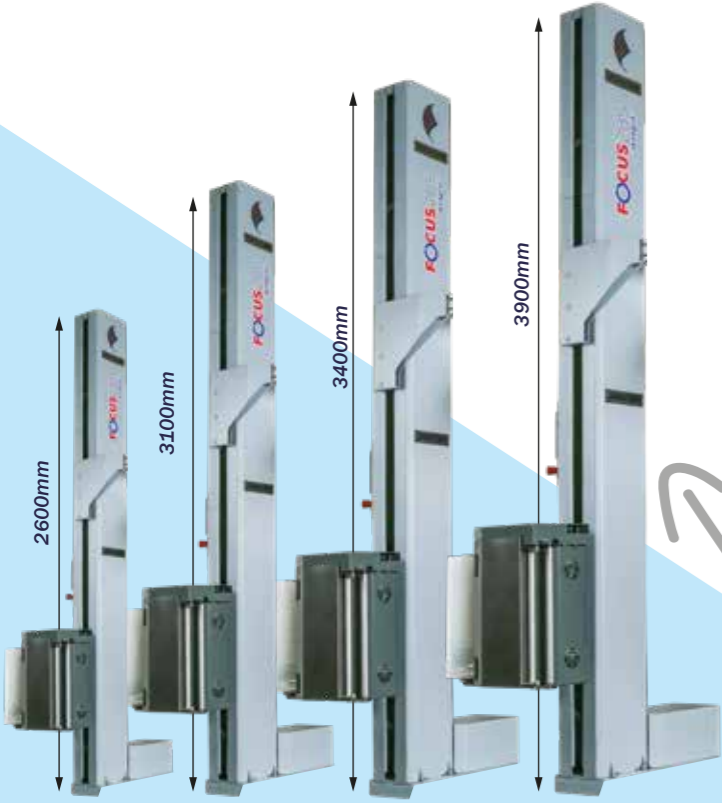

OPSİYONEL SARIM YÜKSEKLİĞİ
Optional Wrapping Height

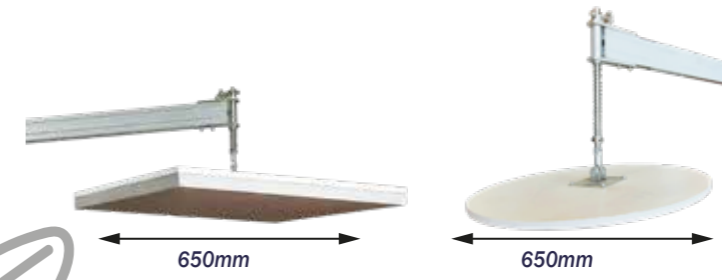

OPSİYONEL ÜST BASKI MODÜLÜ
Optional Overhead Press Module



OPSİYONEL TRANSPALET GİRİŞİNE UYGUN TABLA
Table Suitable For Optional Pallet Truck Input



OPSİYONEL STREÇ KESİM MODÜLÜ
Optional Stretch Cutting Module

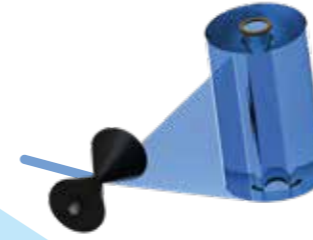

OPSİYONEL İP ATMA MODÜLÜ
Optional Roping Module

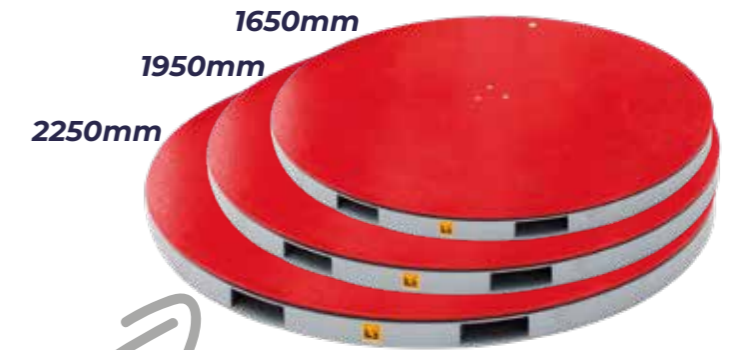

OPSİYONEL TABLA ÇAPI
Optional Table Diameter



OPSİYONEL TARTIM MODÜLÜ
Optional Weighing Module

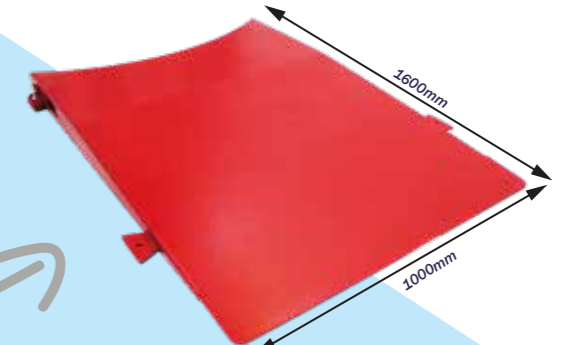

OPSİYONEL PALET YÜKLEME RAMPASI
Optional Pallet Loading Ramp

7" DOKUNMATİK PANEL 7" Touchscreen

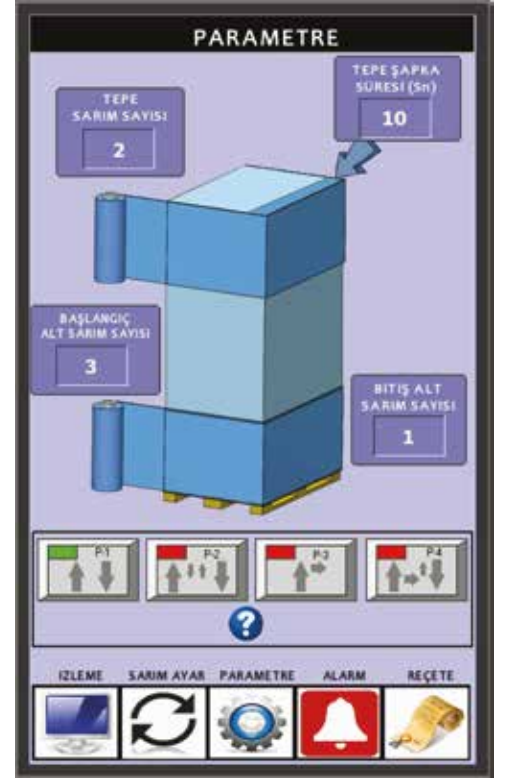
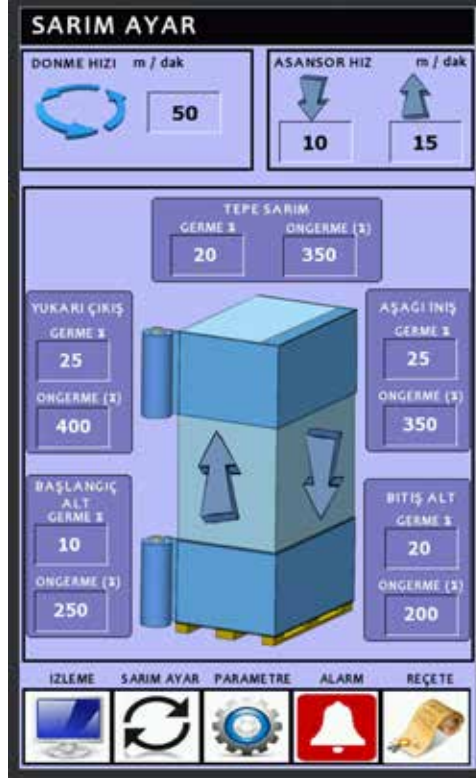

Nakliye esnasında paletleriniz devriliyor mu? Burkuluyor mu?

— Motorlu öngermeli makinalar streci maksimum noktada gerdirdiği için yükleriniz taşıma esnasında burkulmaz devrilmez.

Are your pallets buckling or overturning during the shipping?

— Loads will not buckle or overturn during transportation thanks to the motorized pre-stretching machines that stretch the film at the maximum point.

Streç makinenizin öngermeli teknolojisi nedir?

— Motorlu öngermeli makinalar daha az streçle daha sağlam streçleme yapar.

What is the prestretching technology of your wrapping machine?

— Wrapping machines, with motorized prestretching, wrap stronger with less stretch film.

Palet sararken paranız boşa mı gidiyor?

— %75'e varan streç tasarrufu ile sizleri 100'lerce dolar masraftan kurtarır.

Is your money wasting while pallet wrapping?

— Up to 75% stretch saving provides you 100's of dollars saving per month.

Yeni makine yatırımında amorti süresi ne kadardır?

— Odaksan teknolojisi ile 5000-10000 palette makinenizi amorti edebilirsiniz.

What is the return of the machine investment?

— Odaksan Technology provides short return of investment period.



Merkez

Sanayi Mh. 60363 Cd.
Modern S.S. NO:38
Şehitkamil/GAZİANTEP

+90 552 440 57 50

+90 (342) 218 02 02

Gaziantep-Teknopark

Gaziantep Üniversitesi
Teknopark4-A Blok No:110
Şahinbey/GAZİANTEP

+90 552 817 51 13

İstanbul-Anadolu

Des Sanayi Sitesi
Dudullu Cd. Sokak:110 No:20,
Ümraniye/İSTANBUL

+90 539 272 72 13

İstanbul-Avrupa

İkitelli OSB /İSTANBUL

+90 552 864 51 13

İzmir

Egemenlik Mah. 6106/21 SK.
NO 8 Bornova/İZMİR

+90 532 131 97 92

+90 (232) 231 53 43

Tekirdağ

Şeyh Sinan Mah.
Salih Omurtak Cad. No:225/1A
Çorlu /TEKİDAĞ

+90 532 607 01 23

+90 (282) 653 0 653

Ankara

Ostim Mah. 100. Yıl Bulvarı
No:55 B Blok Daire No:42
Yenimahalle/Ankara

+90 552 790 27 50

Adana

Seyhan/ADANA

+90 552 403 51 13